

# Multi-Directional 3-D LEM Slope Stability

Murray Fredlund

SoilVision Systems Ltd., Saskatoon, Canada, murray@soilvision.com

HaiHua Lu

SoilVision Systems Ltd., Saskatoon, Canada, hailu@soilvision.com

Matthew Donaldson

SoilVision Systems Ltd., Saskatoon, Canada, matt@soilvision.com

Gilson Gitirana, Jr.

Universidade Federal de Goias, Goiania, Brazil, gilsongitirana@ufg.br

**SUMMARY:** The limit equilibrium method (LEM) has been a main-stay of analysis for geotechnical engineers for decades. Applied typically in a 2-D plane strain condition the method has been extended in formulation to the method of columns in 3-D and is now gaining increased use in industry. The formulation of the 3-D method of columns has typically been presented in Cartesian coordinates and with the assumption that the slip direction is in the direction of positive or negative x-coordinates. This assumption severely limits the application of the method in a 3-D environment where the slip direction may be a searching parameter. This paper presents an extended 3-D solution method which allows solution of the 3-D method of columns at any slip direction. This extension will then allow the 3-D LEM to be applied to a broader class of typical geotechnical engineering calculations.

**KEYWORDS:** Slope Stability, 3-D Slope Stability Analysis, 3-D Limit Equilibrium

## 1 INTRODUCTION

The traditional application of the limit equilibrium method (LEM) has been in the context of a 2-D plane strain analysis. Geotechnical engineers have become complacent with the use of 2-D slope stability as it is easy to perform. 2-D analysis suffers from fundamental limitations foremost of which i) the slip shape is assumed to be cylindrical, and ii) the slope geometry is assumed to be unchanged in the 3rd dimension. Such assumptions have proven 2-D analysis to be conservative with respect to the true 3-D factor of safety in the amounts between 10-100% (Domingos, 2016). If unsaturated aspects of slope stability are considered then the difference can be as high as 60% (Lulu, 2015). Therefore, significant opportunity exists to optimize

existing designs through the application of 3-D slope stability analysis. It should be noted that the difference between a 2-D and a calculated 3-D factor of safety is different in each situation. Therefore, it is impossible to assume a specific 2-D/3-D difference for a particular scenario.

The application of software tools to analyze slope stability in 3-D has traditionally been highly limited. Recent developments allow for the easy application of 3-D stability analysis in typical problems. The SVSLOPE software developed by SoilVision Systems Ltd. is utilized for the analysis presented in this paper. The application of 3-D slope stability LEM in practical geotechnical analysis requires two additional searching parameters to be determined; namely, i) aspect ratio (assuming an ellipsoidal slip surface), and ii) slip direction. This paper will focus on the determination of

slip direction in a 3-D LEM stability analysis.

The theory for the 3-D LEM has been in existence for decades and is therefore not new. Early theoretical development efforts are available in research literature (Howland, 1977; Hungr, 1987, Hungr et al., 1989, and Fredlund, 1977). The primary limitation of all presented theory is that the slip direction is assumed to happen exactly along the x-coordinate axis. Such a limitation introduces a significant problem for the practical application of 3-D slope stability analysis. This paper presents an extension to the traditional 3-D LEM which allows for the analysis of slips at any direction. Several benchmark examples are presented such that the implementation of the methodology is proven sound. The technique may be applied to Bishops, Morgenstern-Price, GLE, Spencer's and other analysis methods.

## 2 METHOD

The 2-D LEM is an upper-bound method. This means that the critical slip surface is typically determined through a searching procedure which considers a number of slip surface trials. The resulting critical slip surface is selected as the slip surface which is kinematically admissible and produces the lowest FOS.

In a similar manner it is appropriate to search in a 3-D analysis for slip directions through a range of values. In most scenarios the plotting of FOS versus slip direction should yield a U-shaped function of which the most critical slip direction can be selected as the direction which yields the lowest factor of safety.

It should be noted that such a method assumes a single slip direction in 3-D and does not consider cases where there may be multiple movement directions or sequentially initiated failure blocks.

Two conical example models are utilized in the present study to confirm that the multi-directional methodology in this study is correct. The two examples are presented in the following sections.

## 3 EXAMPLE – CONICAL PIT

The first example is an inverted cone representing a pit excavation. The cone is perfectly symmetrical such that the 3-D factor of safety (FOS) calculated at any particular angle out from the center of the pit should yield the same value. The pit depth is 40 m. The pit example may be seen in Figure 1.

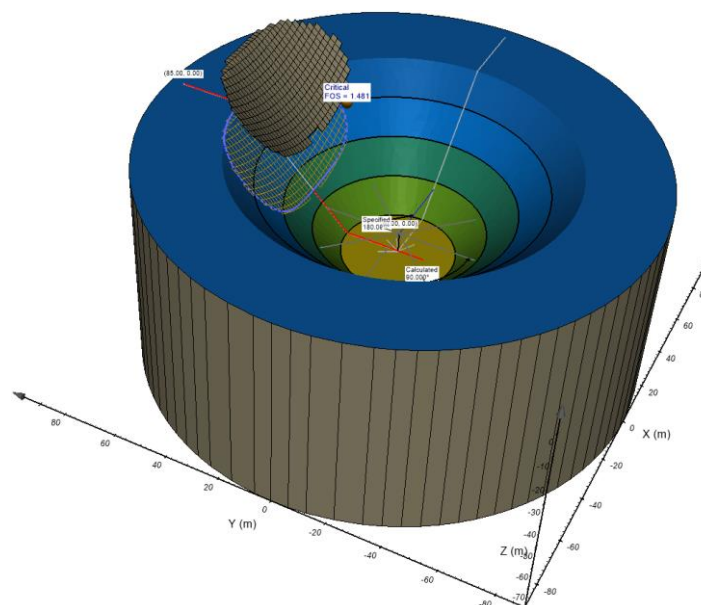

Figure 1. Critical slip surface for a multi-directional analysis of a conical pit example.

The model is set up such that a slip direction in all four directions as well as an intermediate direction halfway between each of the four directions is analyzed. The slip direction is rotated around a point at the center of the bottom of the pit such that the geometry of the slip surface is identical in any direction. The entry and exit method of analysis is used for each slip. As a secondary note, the location of the critical slip surface must be the same for each direction.

The FOS versus each slip direction angle is shown in Figure 2. As the number of columns in the analysis is increased the variance in the FOS at each angle decreases. The minor oscillation of the FOS is induced by differences observed in the elevation of the column top center points. An interpolation algorithm was used to define these coordinates, based on a regular grid of elevation coordinates. Not much refinement is required to reduce these oscillations to negligible amplitudes.

The conical mound is also perfectly symmetrical and slip directions are analyzed in all four directions radiating out from the top / center of the mound. Since the mound is perfectly symmetrical a slip in any direction should yield exactly the same FOS and therefore the ability of the multi-directional method to calculate a slip in any direction can be tested. The conical mound may be seen in Figure 3.

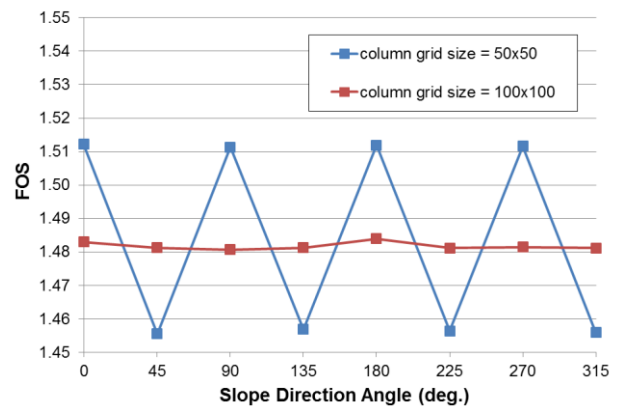

Figure 2. FOS versus slip direction angle.

#### 4 EXAMPLE – CONICAL MOUND

Likewise, the second example is a conical mound of material which is exactly 40 m high.

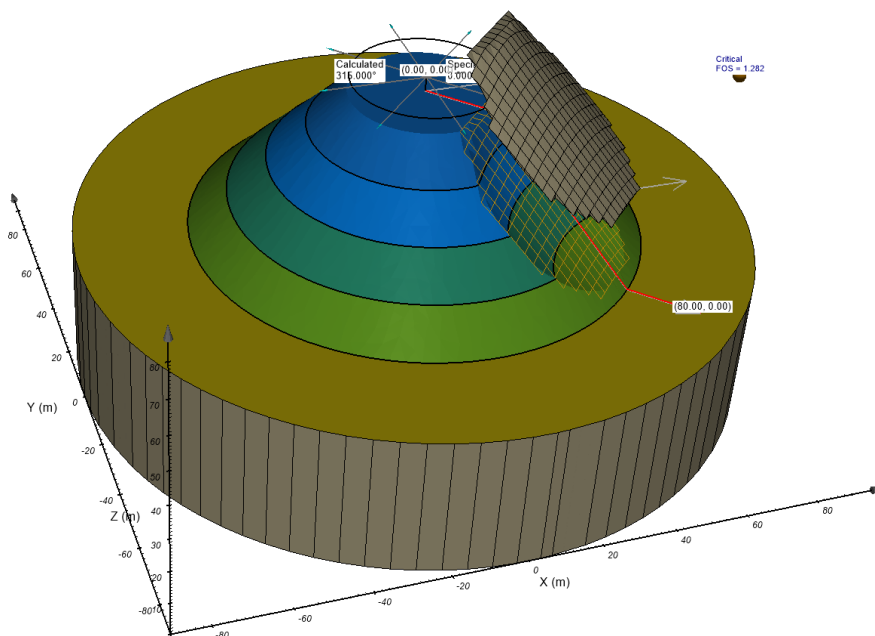

Figure 3. Critical slip surface for a multi-directional analysis of a conical mound example.

Both conical examples assume a homogeneous material of typical properties with a friction angle = 40 degrees and a cohesion of 12 kPa. The cohesion value was chosen simply to have a reasonable depth of slip surface and therefore represent average properties for a cohesive material. In theory, the analysis method should yield the same calculated FOS for any isotropic material properties. The FOS versus each slip direction angle is shown in Figure 4. Similar to the pit example in the previous section, as the number of columns in the analysis is increased the variance in the FOS at each angle decreases.

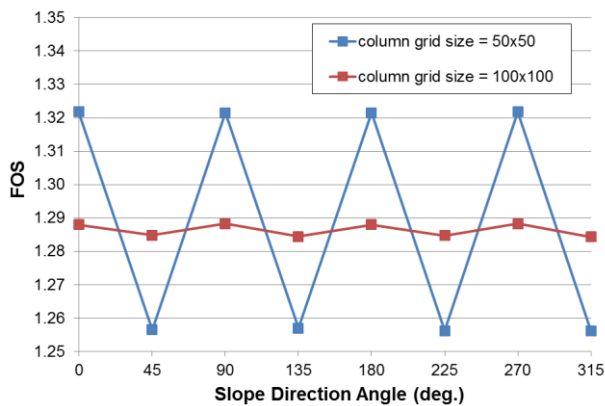

Figure 4. FOS versus slip direction angle.

## 5 EXAMPLE – HILLSIDE

The Hillside example was originally presented by Jiang (2003) and is a classic example of a slope which cannot be easily analyzed using the 2-D LEM. This problem is indicative of a hillslope which may be developed in the course of natural municipal design. The difficulty with this example is that there is a fundamental 3-D aspect to the slope geometry and therefore the slip direction and location of the critical slip surface are unknown. Therefore, an analysis of this slope must consider both location and direction of slippage.

Such a slope may be analyzed through analysis of setting up trial slip directions. Each slip direction in this analysis is input first by the user and then trials of +/- 15 degrees are performed to ensure that the proper slip direction is selected. One slip direction is

analyzed per model and the global minimum can then be determined. A typical analysis of a slip direction can be seen in Figure 5. When a series of analysis are performed along the slope it can be determined that the most likely slip direction is as displayed in Figure 6.

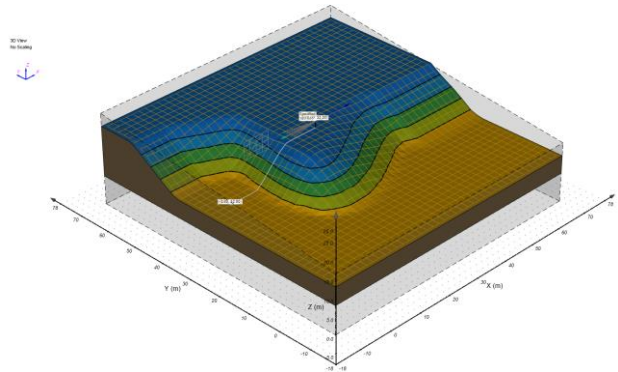

Figure 5. Hillside 3-D slope stability analysis example (Jiang, 2003).

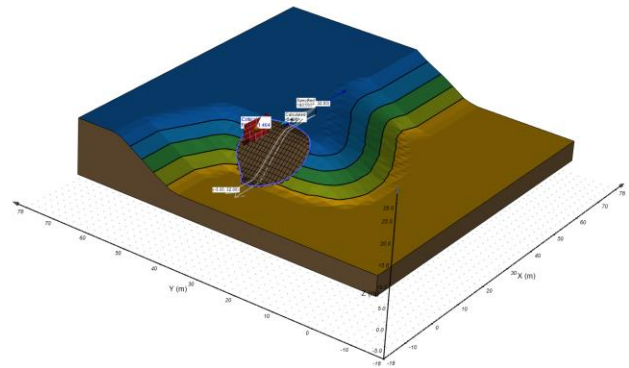

Figure 6. Hillside critical slip direction determined from multi-directional analysis.

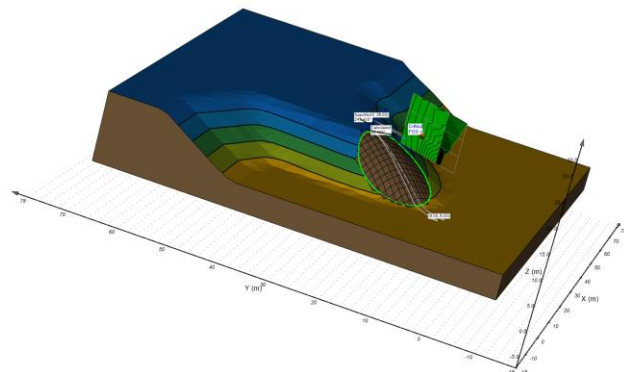

Figure 7. Typical solution of hillslope analysis.

It can be seen that the critical slip surface and direction is on the left of the jut-out which is

somewhat counter intuitive. Intuitively there would be the traditional assumption that the critical slip direction would be near the most convex portion of the slope as shown in Figure 7. The fact that this is not numerically true illustrates the need for analysis methods which computationally determine the location of the most critical failure zone.

## 6 EXAMPLE – OPEN PIT

Such a methodology as presented in this paper is highly conducive to the analysis of slopes typically found in a mining open-pit (Fredlund, 2015), heap leach operations (Reyes, 2014), or waste rock slope stability calculations (Reyes, 2014). In this paper the authors will focus on an example open-pit application. The analysis of such slopes can happen in directions inclusive of the full 360 degrees. Open pit geo-strata geometry can also be difficult to represent in a

numerical model and therefore it is even more difficult to analyze if the restriction is present that the slip direction must always be in the x-axis direction. Typical open pit geometry may be seen in Figure 8.

The methodology allows the user to select any particular slip direction as a “trial slip direction”. A range of slip directions may then be tried and the FOS computed such that the minimum FOS and the optimal slip direction can be determined.

It is recognized that highly complex geometrical features related to geo-strata or faults can exist in open pits. The multi-directional analysis can take into account such complex geometries represented as meshes such that failures influenced by complex geometries can be analyzed. An example of the critical failure surface composed of a composite ellipsoid with the failure plane truncated along a fault plane can be seen in Figure 9.

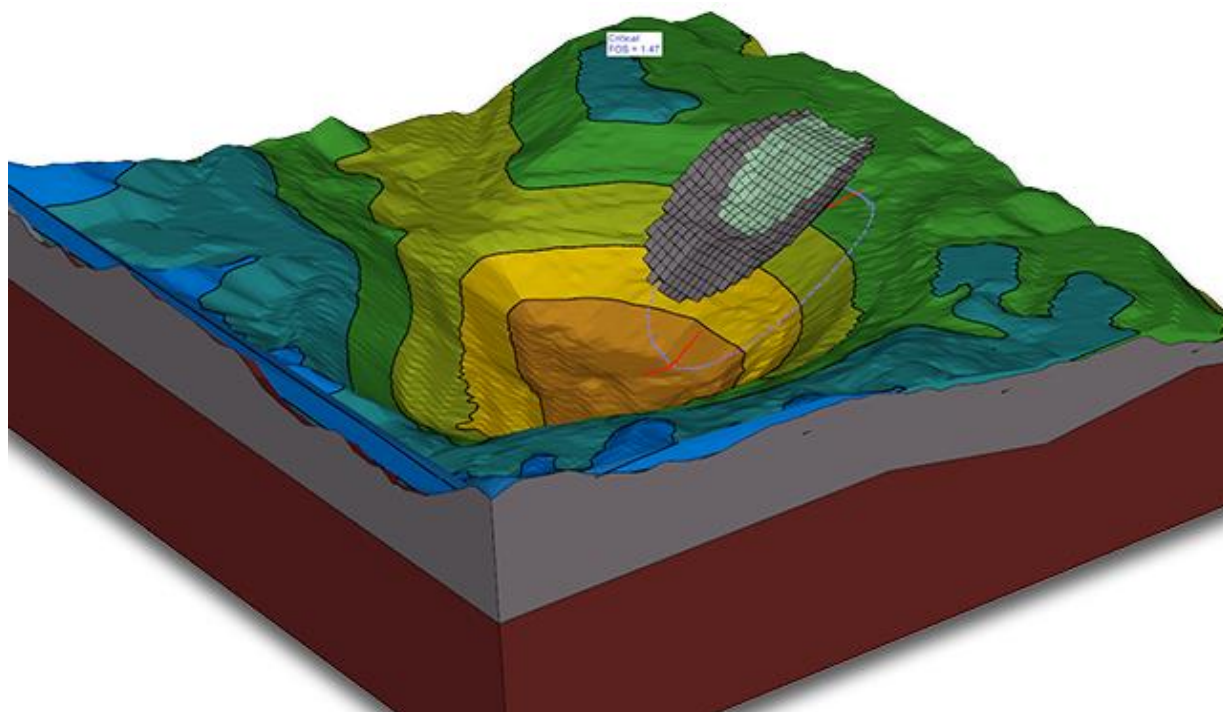

Figure 8. Typical open pit with slope stability analysis performed.

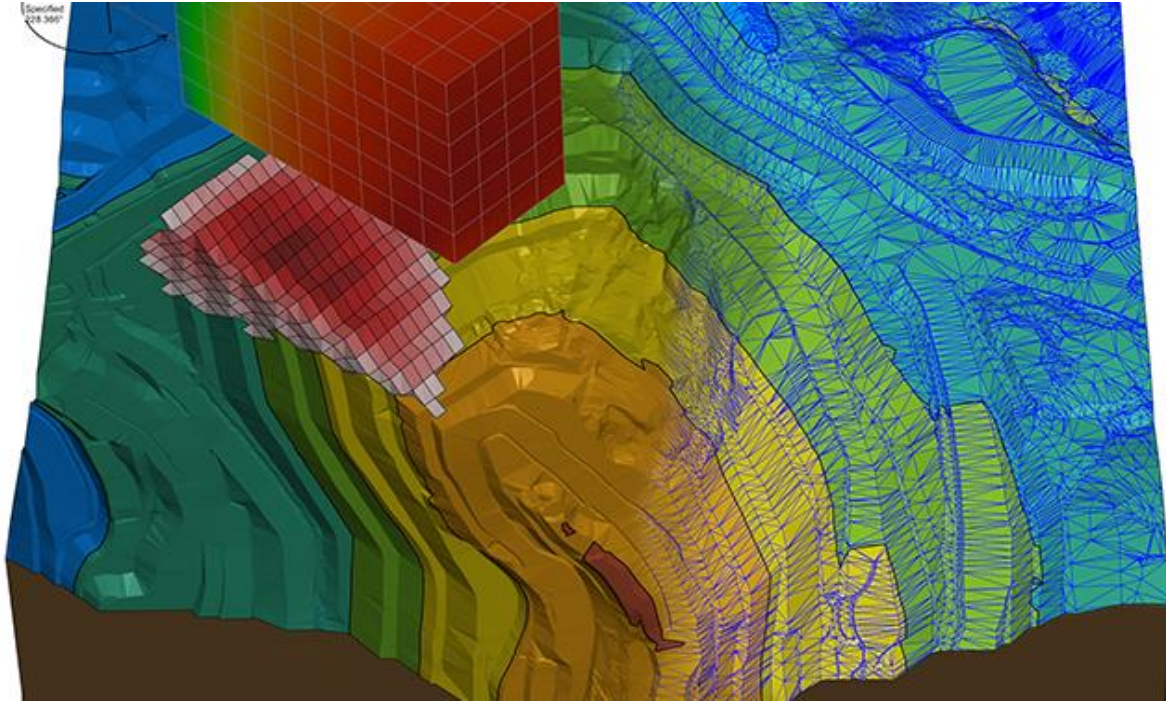

Figure 9. Example failure mass considering fault planes.

## 7 CONCLUSIONS

As a result of the analysis carried out in this paper it may be concluded that an extended 3-D methodology has been successfully developed and implemented that can calculate the slip direction at any angle for a general 3-D LEM analysis. It is noted in the analysis that the resolution of columns selected for the analysis is important and may influence the results. Enough columns must be selected such that the desired accuracy levels can be achieved. The speed of analysis of the 3-D LEM means that the number of columns can be increased without having an overly significant impact on the execution time.

A practical analysis of the Hillside model illustrates the application of the 3-D LEM in order to analyze slope stability conditions not previously possible. Such a Hillside model cannot be analyzed properly in 2-D and the location and direction of a slip remain necessary to determine as part of the analysis. The multi-directional technique makes it easy to quickly analyze such a scenario and determine the most critical portion of the slope as well as the critical slip direction.

The analysis of an open pit illustrates the application of the software to the analysis of complex geo-strata conditions such as present in mining open pits. The multi-directional technique is particularly applicable to the analysis of such geotechnical scenarios such that the FOS can be analyzed quickly at a variety of slope directions.

This study illustrates that it is possible to build a geotechnical 3-D site and potentially analyze the slope stability at a multitude of potential directions. Such an analysis can be carried out without having to rotate site geometry and therefore greatly reduces analysis times.

## REFERENCES

- Andrés R., Pilar G., Denys P. (2014). 3-D Slope Stability Analysis of Heap Leach Pads Using the Limit Equilibrium Method, *Heap Leach Solutions*, November 10 - 13, Lima, Peru.
- Andrés R., Denys P. (2014). 3-D Slope Stability Analysis by the Limit Equilibrium Method of a Mine Waste Dump, *Tailings and Mine Waste 2014*, October 5 - 8, Keystone, CO, USA.
- Domingos, V.H. (2016). Three-Dimensional Slope Stability Using the Limit Equilibrium Method. *M.Sc.*

- dissertation*. Federal University of Goias, Goiania, Brazil.
- Hungr, O. (1987). An Extension of Bishop's Simplified Method of Slope Stability Analysis to Three Dimensions. *Geotechnique*, Vol. 37, No. 1, pp. 113-117.
- Hungr, O. (1997). Slope Stability Analysis. Keynote paper, *Proc., 2nd. Panamerican Symposium on Landslides*, Rio de Janeiro, Int. Society for Soil Mechanics and Geotechnical Engineering, 3: 123-136.
- Hungr, O., Salgado, E.M., and Byrne, P.M. (1989). Evaluation of a Three-Dimensional Method of Slope Stability Analysis. *Canadian Geotechnical Journal*, Vol. 26, pp. 679-686.
- Jiang, J.-C., Baker, R., and Yamagami, T. (2003). The Effect of Strength Envelope Nonlinearity on Slope Stability Computations, *Canadian Geotechnical Journal*, Vol. 40, No. 2, pp. 308-325.
- Lam, L. and Fredlund, D.G. (1993). A General Limit Equilibrium Model for Three-Dimensional Slope Stability Analysis. *Canadian Geotechnical Journal*, Vol. 30, pp. 905-919.
- Fredlund, M., Lu, H., Myhre, T., and Mercer, K. (2015). Open Pit 3-D Limit Equilibrium Numerical Modelling of Complex Geostructures, The Southern African Institute of Mining and Metallurgy Slope Stability 2015.
- Zhang, L., Fredlund, M., Fredlund, D.G., Lu, H., and Wilson, G.W. (2015). The Influence of the Unsaturated Soil Zone on 2-D and 3-D Slope Stability Analyses, *Elsevier - Engineering Geology*, May 14, 2015.
- Zhang, L., Fredlund, M., Fredlund, D.G., Lu, H. (2014). Comparison of 2-D and 3-D Slope Stability Analysis for Unsaturated Slopes, *67th Canadian Geotechnical Conference Regina*, GeoRegina 210, SK, Canada Sept 28 - Oct 1, 2014.